



## Washer disinfectors

### **TIVA10-1M, TIVA10-1M-HS, TIVA10-2M, TIVA10-2M-HS**

Cat. No. MAN205-0715001EN Rev. A

**Tuttnauer Europe B.V.,**

Hoeksteen 11 4815 PR P.O. Box 7191 4800 GD Breda,

The Netherlands ☎ Tel: 31 (0) 765423510, ☐ Fax: 31 (0) 765423540

## ENGLISH

_General updating	00	18/12/2018	F.Stefani	M.Pozzebon	M.Pozzebon
DESCRIPTION	REV.	DATE	PREPARED BY	CHECKED BY	APPROVED BY

<b>INTRODUCTION .....</b>	<b>2</b>
<b>GENERAL SAFETY RULES .....</b>	<b>3</b>
<b>1 INTENDED USE: .....</b>	<b>7</b>
<b>2 PROGRAMMING.....</b>	<b>7</b>
2.1 Menù structure:.....	7
2.2 Instrument washer parameters: .....	9
<b>3 ALARM MESSAGES: .....</b>	<b>15</b>
<b>4 CYCLE COUNTER: .....</b>	<b>19</b>
<b>5 CHEMICAL PRODUCTS CALIBRATION.....</b>	<b>20</b>
5.1 Preparation for calibration of chemical products: .....	20
5.2 Chemical products calibration:.....	21
<b>6 SETTINGS AND MESSAGES MENU .....</b>	<b>21</b>
<b>7 MAINTENANCE.....</b>	<b>24</b>
7.1 External cleaning of the machine:.....	24
7.2 Cleaning of the filters inside the machine:.....	25
7.3 Cleaning of the filters for water loading: .....	25
7.4 Cleaning of the Impeller: .....	26
7.5 Door adjustment: .....	27
7.6 Door limit switch adjustment: .....	27
7.7 Door lock adjustment: .....	27
7.8 Periodic maintenance:.....	28
<b>8 TEMPERATURE TEST.....</b>	<b>30</b>
<b>DIAGRAMS .....</b>	<b>31</b>

## INTRODUCTION

The use of the equipment is easy and intuitive. However, the machine should be solely used by staff trained on each part of this manual. The manual must accompany the machine or must be easily consultable during use. The MANUFACTURER service department is always available for further inquiries or direct intervention. The manual provides proper instructions for machine use, maintenance, installation, dismantling and transportation.



This symbol shows a warning concerning the equipment **USER**.

The user **SHOULD NOT** attempt any maintenance and must simply use the equipment replacing consumable liquids when required.



This symbol indicates a warning concerning a routine or unscheduled maintenance operation which should be strictly performed by trained staff, aware of both the techniques and steps to be carried out to operate the equipment in the event of malfunctioning or failure.



When this symbol appears the staff is required to contact the MANUFACTURER service department, or the nearest service centre, as soon as possible, so that a qualified technician, authorized by THE MANUFACTURER, performs the maintenance operations required.



The symbol on the side indicates that the action requires the operator to be particularly careful.

This symbol is also used on the machine in specific parts that, before being accessed, require the documentation attached to be carefully read.



The symbol on the side indicates that the operation in question involves electrocution risks and therefore the operator must pay special attention.

This symbol is also used on the machine in the vicinity of high-voltage devices.



The symbol on the side indicates that the operation in question involves burn risks (hot surface of the material) and therefore the operator must pay special attention to carry it out. This symbol is also used on the machinery in the vicinity of surfaces that can be very hot.

## **GENERAL SAFETY RULES**

### **FOR SAFETY REASONS PLEASE READ THE FOLLOWING INFORMATION**

Do not cover for any reason the labels placed on the machine and replace them immediately if damaged.

The socket for the power supply must be provided with approved grounding system.

Do not use the machine in an explosive atmosphere.

Do not use the machine to wash or disinfect objects and/or containers that, because of their shape or constituting material, are not compatible with the indications given by the manufacturer.

For objects and/or containers allowed please follow the instructions explicitly indicated in this manual.

In case of long downtime period of the machine cut the power supply off and turn off the water taps.

Do not try to open the door of the tank during operation: the device is equipped with a special safety lock system preventing the door from being opened during operation.

Installation, removal, maintenance, adjustments or any kind of intervention that requires guards to be removed or panels to be opened with wrenches **SHOULD BE CARRIED OUT BY QUALIFIED AND AUTHORIZED STAFF IN ACCORDANCE WITH THE INSTRUCTIONS GIVEN BY THE MANUFACTURER.**

Work on the electrical and plumbing systems, needed to prepare the site where the machine will be installed, must be carried out by qualified staff according to current standards and in a high professional way.

For any maintenance, cut the power supply off by acting on the multi-pole circuit breaker installed upstream of the equipment.

Also take all the necessary safety measures as, by cutting the power supply off, some of the protections provided by the manufacturer could be disconnected.

This equipment must be used by adults who are aware of the information given in this manual.

Do not change, for any reason, the characteristics of the equipment, its installation specifications and the parameters set.

At the end of goods to be used loading and downloading, always close the door of the washing tank in order to avoid possible unpleasant smells coming from the drain.

In case of fire, to extinguish the flames, intervene with a powder fire extinguisher, **DO NOT USE WATER.**

Do not wash the machine with direct or pressure water jets, or corrosive substances.

In case of malfunctioning ascertain they are not due to lack of routine maintenance, otherwise please contact the MANUFACTURER service centre. Repairs not carried out by staff specifically trained by THE MANUFACTURER can cause further damage to property and/or injury to people.

If one or more components of the equipment must be replaced always use original THE MANUFACTURER SPARE PARTS. Only use products recommended by THE MANUFACTURER in this manual.

The machine must not be dumped when scrapped, as it contains materials subject to legislation requiring disposal at special centres.

Make sure that the floor is suitable to support the load of the equipment when in operation, equal to 350 Kg. The machine does not cause harmful vibrations.

Before installing the equipment, ensure that the supply voltage complies with the one shown on the identification plate and that the water supply pressure is that indicated in the technical data.

Ascertain then that the drain matches the dimensions provided on the installation drawing.

During the installation does not pinch the power cable or water hoses.

If your new machine is damaged, contact your dealer before operating it.

The machine is intended for the treatment and thermo-disinfection of instruments for medical use.

The machine is a NON-STERILE device.

Any use other than the machine was intended for is forbidden.

The user is forbidden to carry out any sort of repair.

The technical service to this machine should only be carried out by QUALIFIED AND AUTHORIZED OPERATORS.

Do not expose the product to freeze.

The electrical safety of this machine is only assured if it is connected to an efficient grounding system.

Be very careful when handling detergents and additives. Avoid contact, wear gloves and always meet the safety requirements specified by chemical manufacturer.

Avoid inhaling chemicals. The chemicals are irritating to the eyes, in case of contact wash thoroughly with water and seek for medical advice. In case of contact with skin, wash thoroughly with water.

The water in the tank is not drinkable

Do not lean on the door and do not use it as a step.

The machine, during its work cycle, reaches a temperature of 95° C; be very careful; there may be a danger of scalding.

Failure to comply with these rules may jeopardize the safety of the device and IMMEDIATELY VOID THE WARRANTY.

Do not use the machine without securing it to the ground using the fixing kit supplied with it.

Do not install the machine in the same rooms where patients are housed.

The machine can heat the environment, thus increasing humidity.

Product validation has been performed by the manufacturer in compliance to EN 15883 for an expected life of 10 years; the validation of the disinfection process is on charge of the user.

### Safety instructions for maintenance staff:

Risks for the maintenance of components inside the machine:



Burns of body parts due to contact with the hot parts of the equipment.

Allow only trained and qualified staff, wearing suitable safety clothes, to carry out maintenance operations. Wear appropriate clothing and protection gloves.



Electric shock

Disconnect the power supply before working on machine inner parts.



Contact with liquid chemicals

Always use personal protective equipment (ppe-goggles and gloves) for the eyes and hands.



- The operator must monitor the machine during the cycle;
- Connection with the washing water injection pipe must always be carried out with an appropriate basket;
- During the operation does not interrupt the cycle, otherwise disinfection will be impaired;
- Use only the recommended cleaning agents and chemical additives. The use of other products can damage the machine;

- The fact of recommending chemical additives does not mean the manufacturer assumes liability for any damage to materials and objects to be treated;
- Strictly observe the instructions given by chemical manufacturers. Only use the products complying with their intended use;
- The machine is designed to function with water and chemical additives. Do not use organic solvents or others, they may result in a risk of explosion or rapid deterioration of some machine parts;
- Residues of solvents or acids, in particular "hydrochloric acid", can cause damage to the steel; avoid any contact;
- Only use original accessories;
- Never use detergent powder;
- Never use foaming detergents;
- The machine must be used only with baskets and/or accessories supplied by the manufacturer;
- The accessories that have not been approved by the manufacturer may affect the results obtained, as well as the user safety;
- Never use chemicals based on chlorides (chlorine bleach, sodium hypochlorite, hydrochloric acid, etc.). These types of chemicals will irreparably damage the machine impairing its integrity.

### **Manufacturer's liability and limits:**

**THE MANUFACTURER SHALL NOT BE HELD RESPONSIBLE FOR FAILURES DUE TO TAMPERING AND/OR INCORRECT APPLICATIONS AND/OR INAPPROPRIATE USE OF THE MACHINE.** The user must follow the requirements specified in the user manual and in particular:

- Always work within the limits allowed by the machine;
- Always carry out constant and careful maintenance;
- Allow machine use only to staff properly trained and educated, having proven skills and attitudes suitable to carry out the job and purposes required;
- Only use manufacturer's original spare parts.

The instructions for installation, maintenance and operation described below, were prepared to ensure a long life, as well as a correct and optimal operation of the machine.

### **Manual:**

This manual should be carefully preserved with the machine for future reference. In case of machine sale or transfer to another user, make sure that the manual accompanies the equipment to allow the new owner to obtain information on its operation and relevant components. The manual represents the state of the art at the time of construction and delivery of the device and is valid for its entire life. To avoid possible injury to persons or property caused by an incorrect translation of the instructions, the customer is recommended Not to perform operations or manoeuvres on the machine if any queries or doubts about the operation to be carried out arise, and to ask the Customer Service for clarifications concerning the instruction concerned. If the manual is lost please the manufacturer for a copy.



## 1 INTENDED USE:

Machine for washing, disinfecting and drying of reusable surgical instruments, anesthesia equipment and other operational utensil (glassware, baby bottles and containers).

Misuse of this equipment can be **DANGEROUS TO HEALTH AND SAFETY OF THE OPERATOR** and can cause severe damage to the machine itself.



If the machine is used in ways other than those intended by the manufacturer, the protection of the unit may be impaired.

### Misuse:

It is forbidden to wash:

- Tools and objects that are completely or partially made of wood ;
- Tools and objects different from stainless ones ;
- Tools and objects made of plastic material not suitable for high temperatures.



If the machine is **NOT USED FOR MORE THAN 24 HOURS**, it is necessary to perform a BGA cycle (Disinfection cycle), in order to avoid contamination.

## 2 PROGRAMMING

### 2.1 Menù structure:

The various options in the menus accessible via the PRG key on the keyboard are shown below. The main commands to navigate in the various options are:

- keys 1 and 2: allow you to move between the various menu items by moving up and down within the screen or to increase and decrease the parameter variables;
- START key: allows you to select an item and access the additional menu of the selected item;
- PRG button: allows you to go back or exit a previously selected menu.

### General:

- Program start mode
- Printer activation
- Cycle end buzzer
- Alarm buzzer
- Button press buzzer
- Select language
- After alarm restart mode
- Button 1 program
- Button 2 program
- Button 3 program
- N° cycles for programmed maintenance
- Demi water missing
- Hot water missing
- Chamber light on
- Pass-through window

### Chemicals prod.:

- 1 impulse max time
- Delta ml product
- Sensor 1 cycles number
- Sensor 2 cycles number
- Sensor 3 cycles number
- Sensor 4 cycles number
- Time for 100ml prod.1
- Time for 100ml prod.2
- Time for 100 ml prod.3
- Time for 100 ml prod.4
- Ml prod. 1
- Ml prod. 2
- Ml prod. 3
- Ml prod. 4
- T. Max 1 pulse calibration
- Adjustment imp/ml

### Delays time:

- Load d.l. closing max time
- Unload d.l. closing max time
- Load d.l. opening max time
- Unload d.l. opening max time
- Alarm 42 delay time
- Alarm 70 delay time
- Alarm 71 delay time
- Alarm 40 delay time
- Alarm 6 delay time
- Alarm 2 delay time

### Wash:

- Prewash max temperature
- Chamber max temperature
- Control min. Temperature
- Temperature max difference
- 1°c increment max time
- Condenser jet on temperature
- Condenser jet off temperature
- Water pump on time
- Water pump off time
- Phase max over temperature

### Water:

- Cold water filling max time
- Hot water filling max time
- Demi water filling max time
- Impulse number reg. On 1l
- Max control I
- Min control I

### Regeneration:

- Pause time
- Water filling time
- Rinse water filling time
- Regeneration

### Boiler:

- Enable boiler 1
- Enable boiler 2
- Temper. Off boiler 1
- Time open in advance
- Time charge boiler 1
- Time to increase 1°C boiler 1
- Max time drainage boiler 1
- Max temperature boiler 1
- Drainage time boiler 1
- Histeresis temper. Boiler 1
- Off temperature boiler 1 st-by
- Charging time boiler 2
- Time to increase 1°C boiler 2
- Max drainage time boiler 2
- Max temperature boiler 2
- Drainage time boiler 2
- Histeresis temper. Boiler 2
- Off temper. St-by boiler 2
- St-by boiler time
- Add water boiler time

### Alarm setting:

- Management delay
- Yellow dots screen time

### Clock:

### Chose products calibrton:

- Filling hydraulic circuit
- Chemical product calibration

### Spreay arms:

- Impeller b 5 round max time
- Impeller 15 round max time
- Impeller 2 5 round max time
- Impeller 3 5 round max time
- Impeller 4 5 round max time
- Impeller a 5 round max time
- Impeller b stopped max time
- Impeller 1 stopped max time
- Impeller 2 stopped max time
- Impeller 3 stopped max time
- Impeller 4 stopped max time
- Impeller a stopped max time
- Alarm setting
- Management delay
- Yellow spots screen time

### Conduc. Sensor:

- Rinse repetition number
- Conductivity value

### Cycles counter:

### Default:

## 2.2 Instrument washer parameters:

This table shows the parameters of the machine. These parameters can be accessed by technicians only (a password is required).

To enter the parameters two ways are possible:

1. by machine keyboard, holding down for 5 seconds the PRG button, to scroll the menu to the left and right use the buttons "1" and "2", to scroll the menu up and down use the buttons "P+" and "DRY".
2. by external computer connected to the machine and provided with the relative program.

REF.	DESCRIPTION	UNIT	DEFAULT	RANGE
1.01	Max time required for loading area door unit closing	Seconds	8	0-99
1.02	Max time required for unloading area door unit closing	Seconds	8	0-99

REF.	DESCRIPTION	UNIT	DEFAULT	RANGE
1.03	Max time required for loading area door unit opening	Seconds	8	0-99
1.04	Max time required for unloading area door unit opening	Seconds	8	0-99
1.05	Max time required for water flow meters single-pulse detection	Seconds	5	0-99
1.06	Max waiting time for 18L hot + cold water fill the tank	Seconds	350	0-999
1.07	Max waiting time for 18L cold + purified water fill the tank	Seconds	350	0-999
1.08	Max waiting time for 18L hot + purified water fill the tank	Seconds	350	0-999
1.09	Max time required for chemicals one pulse detection	Seconds	20	0-99
1.10	Max draining time	Seconds	80	0-999
1.11	Maximum draining time with cold water load	Seconds	90	0-999
1.12	Alarm 23 time delay	Seconds	15	0-99
1.13	Drying minimum temperature	°C	50	0-99
1.14	Maximum temperature for tank pre-wash	°C	80	0-99
1.15	Tank maximum temperature	°C	102	0-999
1.16	Air probe maximum temperature	°C	162	0-999
1.17	Minimum temperature for maximum difference control between the two PT1000 probes in the tank	°C	80	0-99
1.18	Maximum temperature difference between the two PT1000 probes in the tank	°C	2	0-99
1.19	Maximum time for 1° C increase in the tank	Seconds	300	0-999
1.20	Alarm 39 time delay	Seconds	5	0-99
1.21	Product 1 flow meter pulses	Pulses	20	0-999
1.22	Product 2 flow meter pulses	Pulses	20	0-999
1.23	Product 3 flow meter pulses	Pulses	20	0-999
1.24	Product 4 flow meter pulses	Pulses	20	0-999
1.27	Alarm 47 time delay	Seconds	5	0-99
1.28	Pause time during regeneration	Seconds	600	0-999
1.29	Loading time for regeneration water	Seconds	120	0-999
1.30	Loading time for regeneration rinse water	Seconds	60	0-999
1.31	Maximum waiting time for cold water loading	Seconds	400	0-999
1.32	Maximum waiting time for hot water loading	Seconds	400	0-999
1.33	Maximum waiting time for purified water loading	Seconds	350	0-999
1.34	Cold water flow meter pulses	Pulses	1440	0-9999
1.35	Hot water flow meter pulses	Pulses	1440	0-9999
1.36	Purified water flow meter pulses	Pulses	1440	0-9999
1.37	Maximum number of cycles with product 1 nozzle contact open	No. of cycles	10	0-99
1.38	Maximum number of cycles with product 2 nozzle contact open	No. of cycles	10	0-99
1.39	Maximum number of cycles with product 3 nozzle contact open	No. of cycles	10	0-99
1.40	Maximum number of cycles with product 4 nozzle contact open	No. of cycles	10	0-99
1.41	Alarm 21 time delay	Seconds	10	0-99
1.42	Opening temperature of the solenoid valve jet on condenser	°C	80	0-99

REF.	DESCRIPTION	UNIT	DEFAULT	RANGE
	during disinfection			
1.43	Closing temperature of the solenoid valve jet on condenser during disinfection	°C	91	0-99
1.44	Regeneration with salt (French degrees/number indicating how many times the cold water valve opens): 0-10/never; 10-15/30; 15-20/25; 20-25/21; 25-30/18; 30-35/15; 35-40/12; 40-45/9; 45-50/6; 50-55/3; 55-60/1.	Number	7	1-11
1.45	Number of regenerations before salt refill	Number	8	1-20
1.46	Product 1 flow meter time	Seconds	10	0-99
1.47	Product 2 flow meter time	Seconds	10	0-99
1.48	Product 3 flow meter time	Seconds	10	0-99
1.49	Product 4 flow meter time	Seconds	10	0-99
1.50	Air pump off time at low speed (intermittent)	Seconds	1	0-99
1.51	Air pump on time at low speed (intermittent)	Seconds	4	0-99
1.52	Air pump total intermittent time at low speed	Seconds	120	0-999
1.53	Hysteresis	°C	2	0-99
1.54	Select a program starting mode (0: Manual, 1: Basket recognition; 2: Manual - Basket recognition)	Number	7	1-11
1.55	Water pump on time, loading phase (intermittent)	Seconds	4	0-99
1.56	Water pump off time, loading phase (intermittent)	Seconds	8	0-99
1.57	Printer enabling (0=off; 1=on)	Number	1	0-1
1.58	End of cycle buzzer (0=off; 1=on)	Number	1	0-1
1.59	Alarm warning buzzer (0=off; 1=on)	Number	1	0-1
1.60	Button pressure buzzer (0=off; 1=on)	Number	1	0-1
1.61	Language selection (1,2,3,4,5,6,7,8)	Number	1	1-8
1.62	Restoring mode after an alarm or after a power failure (0= the program resumes operation starting again the phase during which it was interrupted, 1= the program starts from the beginning; 2= the program restarts exactly where it was interrupted; 3= the program does not restart and remains set to standby mode).	Number	0	0-3
1.63	Program selected in position 1 (P1 keyboard)	Number	10	1-40
1.64	Program selected in position 2 (P2 keyboard)	Number	11	1-40
1.65	Program selected in position 3 (P3 keyboard)	Number	12	1-40
1.66	Number of cycles to perform scheduled maintenance	Cycles	500	0-9999
1.67	Number of last alarms occurred that are displayed in the alarm history report	Number	100	0-9999
1.68	Jet condenser solenoid valve opening time	Seconds	60	0-999
1.69	Liquid product 1 inlet time	°C	45	0-99
1.70	Liquid product 2 inlet time	°C	45	0-99
1.71	Liquid product 3 inlet time	°C	45	0-99
1.72	Liquid product 4 inlet time	°C	45	0-99
1.73	Pre-washing time	Seconds	120	0-999
1.74	Washing time	Seconds	60	0-999
1.75	Rinse time	Seconds	30	0-999
1.76	Disinfection time	Seconds	60	0-999
1.77	Delay time for pre-washing tank heating elements activation	Seconds	30	0-999

REF.	DESCRIPTION	UNIT	DEFAULT	RANGE
1.78	Delay time for washing tank heating elements activation	Seconds	30	0-999
1.79	Delay time for washing tank heating elements activation	Seconds	30	0-999
1.80	Delay time for disinfection tank heating elements activation	Seconds	30	0-999
1.81	Drain solenoid valve time on	Seconds	10	0-999
1.82	Drain solenoid valve time off	Seconds	1	0-999
1.83	Advance opening time of the drain solenoid valve with respect to pump shut-down	Seconds	5	0-999
1.84	Cold water loading time at drain solenoid valve opening	Seconds	25	0-999
1.85	Air pump pause time	Seconds	20	0-999
1.86	Air pump activation in continuous mode and at maximum power v = 2800rpm	Minutes	11	0-9999
1.87	Air heating element temperature difference at shut-down compared to average	°C	20	-50/200
1.88	Air heating element temperature difference at start-up compared to average	°C	-20	-50/200
1.89	Air heating element average temperature	°C	100	0-200
1.90	Pre-washing temperature	°C	0	0-99
1.91	Washing temperature	°C	60	0-99
1.92	Rinse temperature	°C	0	0-99
1.93	Disinfection temperature	°C	90	0-99
1.94	Absence of purified water, load cold water. (0=no; 1=yes)	Number	0	0-1
1.95	Absence of hot water, cold water load instead. (0=no; 1=yes)	Number	0	0-1
1.96	Liquid product 1 maximum loading time	Seconds	30	0-999
1.97	Liquid product 2 maximum loading time	Seconds	30	0-999
1.98	Liquid product 3 maximum loading time	Seconds	30	0-999
1.99	Liquid product 4 maximum loading time	Seconds	30	0-999
2.00	Highest temperature measured exceeding the temperature set on each phase	°C	10	0-99
2.01	Programs enabled with basket 1	Number	1,8,10	0-40
2.02	Programs enabled with basket 2	Number	1,2,3,14,15,16	0-40
2.03	Programs enabled with basket 3	Number	6,9,17	0-40
2.04	Programs enabled with basket 4	Number	20	0-40
2.05	Programs enabled with basket 5	Number	1,2,3,4,5,6,7,8,19	0-40
2.06	Loop mode devices time on	Seconds	10	0-9999
2.07	Loop mode devices time off	Seconds	10	0-9999
2.08	Liquid product 1 millilitres	ml	10	0-999
2.09	Liquid product 2 millilitres	ml	10	0-999
2.10	Liquid product 3 millilitres	ml	10	0-999
2.11	Liquid product 4 millilitres	ml	10	0-999
2.12	1 L of water pulse number adjustment	Pulses	80	0-9999
2.13	10 ml of liquid product 1 number of pulses adjustment	Pulses	20	0-9999
2.14	10 ml of liquid product 2 number of pulses adjustment	Pulses	20	0-9999
2.15	10 ml of liquid product 3 number of pulses adjustment	Pulses	20	0-9999
2.16	10 ml of liquid product 4 number of pulses adjustment	Pulses	20	0-9999
2.17	Quantity of cold water in the tank	L	18	0-999
2.18	Quantity of hot water in the tank	L	18	0-999

REF.	DESCRIPTION	UNIT	DEFAULT	RANGE
2.19	Quantity of purified water in the tank	L	18	0-999
2.20	Time adjustment for 10 ml liquid product inlet	Seconds	5	0-999
2.21	Cold water loading for drying	L	8	0-999
2.22	Maximum time of "opposite position" between the contacts of the boiler 2 level probes	Seconds	5	0-999
2.23	Boiler heating element off temperature	°C	90	0-99
2.24	Boiler heating element on temperature	°C	85	0-99
2.25	Machine name	Characters		20car (A-Z; 0-9)
2.26	Air heating element activation delay time	Seconds	5	0-99
2.27	A0 min value	Number	3000	0-65000
2.28	Alarm 6 time delay	Seconds	3	0-999
2.29	Alarm 2 initial delay time	Seconds	2	0-99
2.30	Tank light on time	Seconds	60	0-999
2.31	Boiler drain time	Seconds	20	0-999
2.32	Boiler added water	Seconds	10	0-99
2.33	Boiler unloading maximum time	Seconds	20	0-999
2.34	Boiler 1°C increase maximum time	Seconds	120	0-999
2.35	Boiler water loading maximum time	Seconds	60	0-999
2.36	Additional water loading time	Seconds	1	0-99
2.37	Boiler maximum temperature	°C	98	0-99
2.38	Rotor 1 probe 5 pulses max time	Seconds	4	0-999
2.39	Rotor 2 probe 5 pulses max time	Seconds	4	0-999
2.40	Rotor 3 probe 5 pulses max time	Seconds	4	0-999
2.41	Rotor 4 probe 5 pulses max time	Seconds	4	0-999
2.42	Rotor 5 probe 5 pulses max time	Seconds	4	0-999
2.43	Rotor 6 probe 5 pulses max time	Seconds	4	0-999
2.44	Max time between rotor 1 one pulse and the subsequent	Seconds	10	0-999
2.45	Max time between rotor 2 one pulse and the subsequent	Seconds	10	0-999
2.46	Max time between rotor 3 one pulse and the subsequent	Seconds	10	0-999
2.47	Max time between rotor 4 one pulse and the subsequent	Seconds	10	0-999
2.48	Max time between rotor 5 one pulse and the subsequent	Seconds	10	0-999
2.49	Max time between rotor 6 one pulse and the subsequent	Seconds	10	0-999
2.50	Air heating element activation time	Seconds	600	0-9999
2.51	Rotor probes alarm settings (1= alarm 80 when the rotor, to send 5 pulses to the card, takes more time than the set one at ref. 2:38 - 2:39 - 2:40 - 2:41 - 2:42 - 2:43; 0= alarm 80 when between a rotor pulse and the other more time than that set is passed at ref. 2:44 - 2:45 - 2:46 - 2:47 - 2:48 to 2:49). If the probes of the rotors are disabled the alarm must not occur.	Number	0	0-1
2.52	Repeated rinses with dirty water	Number	3	0-999
2.53	Maximum conductivity value	Number	20	0-999
2.54	Rotor management delay	Seconds	10	0-99
2.55	Passing window	Value	On	On-off
2.56	Rotor time screen yellow dot	Seconds	30	0-99
2.57	Max control L amount	L	17.5	0-99

REF.	DESCRIPTION	UNIT	DEFAULT	RANGE
2.58	Min control L amount	L	16.5	0-99
2.59	LAN network lifetime	Seconds	100	0-99
2.60	Enable conductivity probe	Value	Off	On-off
2.61	Addition time product	Seconds	10	0-99
2.62	ml more than the set value	ml	1	0-99
2.63	Max time 1 pulse in calibration	Seconds	5	0-99
2.64	Pulse/ml adjustment	Value	1	1-100
2.65	Timeout product calibration	Seconds	80	0-999
2.66	A0 priority	Value	Off	On-off
2.67	T. on drain pump standby	Seconds	10	0-999
2.68	T. off drain pump standby	Minutes	60	0-999
2.69	T. on drain pump regeneration	Seconds	10	0-999
2.70	T. off drain pump regeneration	Seconds	60	0-999
2.71	Drain pump abilitation	Value	Off	On-off
2.72	Dry temperature alarm	°C	90	0-99
2.73	Product timeout	Seconds	60	0-999
2.74	Cooling fan functioning time	Seconds	900	0-9999
2.75	Delay time alarm 47	Seconds	60	0-999
2.76	Drainage pump functioning time with alarm	Seconds	60	0-999
2.77	Off temperature boiler 1	°C	60	0-99
2.78	Hysteresis temperature boiler 1	°C	3	0-99
2.79	Drainage time boiler 1	Seconds	10	0-99
2.80	Drainage time boiler 2	Seconds	10	0-99
2.81	Off temperature boiler 1 standby	°C	50	0-99
2.82	Off temperature boiler 2	°C	85	0-99
2.83	Histeresis temperature	°C	2	0-99
2.84	Off temperature boiler 2 standby	°C	65	0-99
2.85	Max charging time boiler 1	Seconds	120	0-999
2.86	Max charging time boiler 2	Seconds	120	0-999
2.87	Max increasing time 1° boiler 1	Seconds	120	0-999
2.88	Max increasing time 1° boiler 2	Seconds	120	0-999
2.89	Max temperature boiler 1	°C	95	0-99
2.90	Max temperature boiler 2	°C	95	0-99
2.91	Time opening in advance than drying phase	Seconds	60	0-999
2.92	Enable boiler 1	Value	0	0-1
2.93	Enable boiler 2	Value	0	0-1
2.94	Time boilers standby	Hour	3	0-99
2.95	Max time drainage boiler 1	Seconds	60	0-999
2.96	Max time drainage boiler 2	Seconds	60	0-999
2.97	Charging time add water for boiler	Seconds	8	0-99
2.98	Single door	Value	Off	On-Off
2.99	Door opening only if there is the release trolley	Value	ON	on - Off
3.00	Door automation	Value	ON	on - Off
3.01	Max time opening/closing/ door	Seconds	20	0-99
3.02	Waste time movement door1/door 2	Seconds	3	1-99
3.05	Time delay relay control voltage reading	Seconds	2	0-99
3.06	Offset tank probe 1	°C	0	-9,9 / +9,9
3.07	Offset tank probe 2	°C	0	-9,9 / +9,9
3.08	Offset air probe	°C	0	-9,9 / +9,9



### 3 ALARM MESSAGES:

The machine displays any alarm messages. Below there is an example of a typical alarm which could appear on the screen.

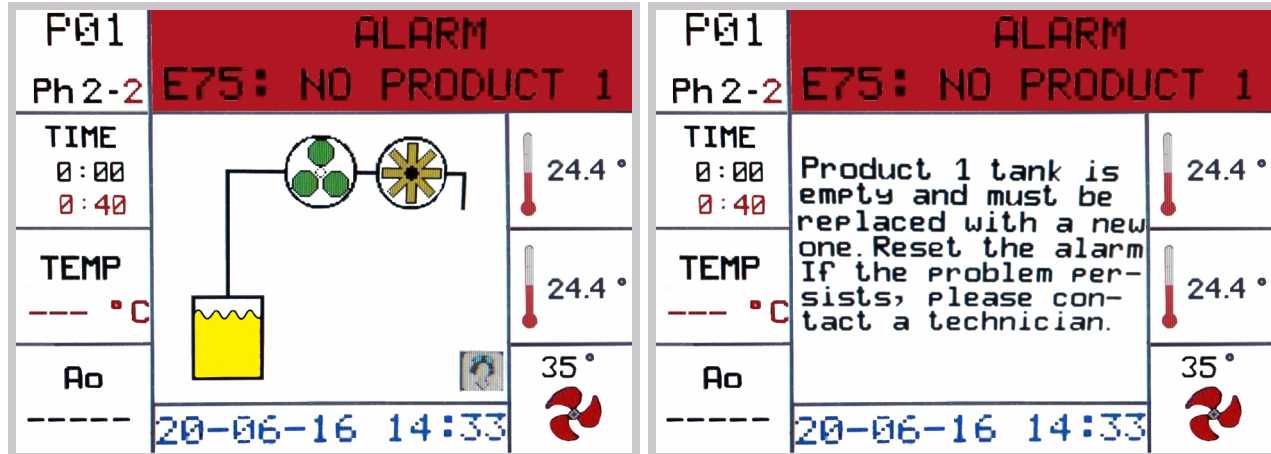

At first the image concerning the alarm is displayed (for 5 seconds); then the alarm description is displayed (for 10 seconds). The image and text alternate until the alarm is reset.

ALARMS	TITLE	DESCRIPTION
E01	BLACKOUT	A blackout occurred during program execution and the program was stopped. Reset the alarm to resume the program previously interrupted.
E02	DOOR 1 OPEN	The load door is open and/or unlocked. Reset the alarm. If the problem persists, please contact a technician.
E03	DOOR 2 OPEN	The unloading door is open and/or unlocked. Reset the alarm and make sure that the door is closed and the handle vertical. If the problem persists, please contact a technician.
E04	DOOR 2 OPEN	The device does not recognize the loading door position. Check the functioning of the door's limits sensors. Reset the alarm. If the problem persists, please contact a technician.
E05	DOOR 2 LOCKED	The unloading door is open but the lock is activated. Please make sure that the handle is vertical. Reset the alarm. If the problem persists, please contact the technician.
E06	DOOR PROBLEM	Both doors are open and/or unlocked. Make sure that both doors are closed and both handles are vertical. Reset the alarm. If the problem persists please contact a technician.
E07	NOT LOCK D.1	The loading door did not close within the preset time. Check for the presence of any obstacle on the door's way and reset the alarm. If the problem persists, please contact a technician.
E08	NOT LOCK D.2	The lock of the unloading door didn't close within the preset time, or, during the activation of door lock, the handle has been moved. Make sure that the handle is vertical and reset the alarm. If the problem persists, please contact a technician.

E09	NOT UNLOCK D.1	The loading door did not open within the preset time. Check for the presence of any obstacle on the door's way and reset the alarm. If the problem persists, please contact a technician.
E10	NOT UNLOCK D.2	The unloading door lock didn't open within the preset timereset the alarm. If the problem persists, please contact a technician.
E11	WATER DIRTY	The program was interrupted because, after several rinses, an acceptable conductivity value of water was not achieved. Check for the presence of dirt residual on the instruments and check the conductivity value of the network water.
E20	NO COLD WATER	The following reasons might have caused the alarm: closed or only partially opened water tap; broken or malfunctioning flowmeter or lack of water in the network. Reset the alarm. If the problem persists, please contact a technician.
E21	NO HOT WATER	The following reasons might have caused the alarm: closed or only partially opened water tap; broken or malfunctioning flowmeter or lack of water in the network. Reset the alarm. If the problem persists, please contact a technician.
E22	NO DEMI WATER	The following reasons might have caused the alarm: closed or only partially opened water tap; broken or malfunctioning flowmeter or lack of water in the network. Reset the alarm. If the problem persists, please contact a technician.
E23	NO HOT+COLD	The following reasons might have caused the alarm: closed or only partially opened water tap; broken or malfunctioning flowmeter or lack of water in the network. Reset the alarm. If the problem persists, please contact a technician.
E24	NO COLD+DEMI	The following reasons might have caused the alarm: closed or only partially opened water tap; broken or malfunctioning flowmeter or lack of water in the network. Reset the alarm. If the problem persists, please contact a technician.
E25	NO HOT+DEMI	The following reasons might have caused the alarm: closed or only partially opened water tap; broken or malfunctioning flowmeter or lack of water in the network. Reset the alarm. If the problem persists, please contact a technician.
E26	PRINTER PAPER	The printer ran out of paper. Please insert a new paper roll in the printer or disable the printer itself if you don't have one.
E30	NO PRODUCT 1	The following reasons might have caused the alarm: the peristaltic pump and/or the flowmeter of prod.1 might be malfunctioning or broken; the silicone hose might be pinched or perforated or the prod.1 tank might be empty. If the tank is empty, please replace it. Reset the alarm. If the problem persists, please contact a technician.
E31	NO PRODUCT 2	The following reasons might have caused the alarm: the peristaltic pump and/or the flowmeter of prod.2 might be malfunctioning or broken; the silicone hose might be pinched or perforated or the prod.2 tank might be empty. If the tank is empty, please replace it. Reset the alarm. If the problem persists, please contact a technician.

E32	NO PRODUCT 3	The following reasons might have caused the alarm: the peristaltic pump and/or the flowmeter of prod.3 might be malfunctioning or broken; the silicone hose might be pinched or perforated or the prod.3 tank might be empty. If the tank is empty, please replace it. Reset the alarm. If the problem persists, please contact a technician.
E33	NO PRODUCT 4	The following reasons might have caused the alarm: the peristaltic pump and/or the flowmeter of prod.4 might be malfunctioning or broken; the silicone hose might be pinched or perforated or the prod.4 tank might be empty. If the tank is empty, please replace it. Reset the alarm. If the problem persists, please contact a technician.
E40	TILT RESISTANCE	There is a problem with the heating elements contactor. Reset the alarm. If the problem persists please contact a technician
E41	TIMEOUT DRAIN	The following reasons might have caused the alarm: the discharge pipe might be clogged or pinched, the discharge solenoid valve might be closed or broken or the pressure switch might be broken. Reset the alarm. If the problem persists please contact a technician.
E42	AIR PRESSURE	The following reasons might have caused the alarm: the air pump might be malfunctioning or broken, there may be a leakage inside the air duct or the pressure switch might be broken. Reset the alarm. If the problem persists, please contact a technician.
E43	T. DRY	The following reasons might have caused the alarm: the air heater or the PT1000 temperature probe placed in the air duct may be broken. Reset the alarm. If the problem persists, please contact a technician.
E44	T. PREWASH	The following reasons might have caused the alarm: the contactor of the resistors inside the water tank or the PT1000 temperature probe placed in the washing chamber may be broken. Reset the alarm. If the problem persists, please contact a technician.
E45	LIMIT T. TANK	The following reasons might have caused the alarm: the contactor of the resistors inside the water tank or the PT1000 temperature probe placed in the washing chamber may be broken. Reset the alarm. If the problem persists, please contact a technician.
E46	AIR T. LIMIT	The following reasons might have caused the alarm: the air heater contactor or the PT1000 temperature probe placed in the air duct may be broken. Reset the alarm. If the problem persists, please contact a technician.
E47	FASE T. LIMIT	The following reasons might have caused the alarm: the air heater contactor or the PT1000 temperature probe placed in the air duct may be broken. Reset the alarm. If the problem persists, please contact a technician.
E50	PROBE 1 BROKEN	The PT1000 master temperature probe is broken or disconnected. Replace or connect it. Reset the alarm. If the problem persists, please contact a technician
E51	PROBE 2 BROKEN	The PT1000 slave temperature probe is broken or disconnected. Replace or connect it. Reset the alarm. If the problem persists, please contact a technician

E52	AIR PROBE KO	The PT1000 air temperature probe is broken or disconnected. Replace or connect it. Reset the alarm. If the problem persists, please contact a technician
E53	TANK T. CHECK	A temperature difference between the two temperature probes higher than the maximum preset has been detected. Check which temperature probe is damaged and replace it. Reset the alarm. If the problem persists, please contact a technician.
E62	BUS CABLE	Make sure that micro board 1 and microboard 2 are connected via cable. Reset the alarm. If the problem persists, please contact a technician.
E66	NO HEATING	There might be an issue with the tank heater. Check for the presence of limescale on the heater and clean it. If the limescale deposit is too thick, replace the heater. Reset the alarm. If the problem persists, please contact a technician.
E67	L. CONDENSER	The water inside the steam condenser has reached the maximum level allowed. This problem can be caused if the discharge pipe is clogged/pinched or the water level probe inside the condenser is broken. Reset the alarm. If the problem persists, please contact a technician.
E70	PUMP PRESSURE	The following reasons might have caused the alarm: the washing chamber pump might be rotating in the wrong direction, the pressure switch might be damage or there might be foam forming during the washing phases. Reset the alarm. If the problem persists, please contact a technician.
E71	HEPA FILTER	The following reasons might have caused the alarm: the Hepa filter might be clogged or dirty or the pressure switch might be broken. Reset the alarm. If the problem persists, please contact a technician.
E75	NO PRODUCT 1	The device has reached the maximum number of cycles that can be performed with the reserve of prod.1. Please replace prod.1 tank with a new one. Reset the alarm. If the problem persists, please contact a technician.
E76	NO PRODUCT 2	The device has reached the maximum number of cycles that can be performed with the reserve of prod.2. Please replace prod.2 tank with a new one. Reset the alarm. If the problem persists, please contact a technician.
E77	NO PRODUCT 3	The device has reached the maximum number of cycles that can be performed with the reserve of prod.3. Please replace prod.3 tank with a new one. Reset the alarm. If the problem persists, please contact a technician.
E78	NO PRODUCT 4	The device has reached the maximum number of cycles that can be performed with the reserve of prod.4. Please replace prod.4 tank with a new one. Reset the alarm. If the problem persists, please contact a technician.
E80	IMPELLER LOCKED	One or more spray arms are blocked. Try to disassemble the arm blocked (indicated by a red dot on display) and clean it. Reset the alarm. If the problem persists, please call a technician.
E81	BOILER 2 CHARGE	The causes can be various: the tap of demineralized water is closed or not entirely open, or for lack of water network

E82	BOIL. 2 HEATING	It is a problem in the heater of boiler 2, check if there is some scale around the heating elements. If there is a lot of scale, is necessary to change the heating elements. Reset the alarm to resume the cycle interrupted before. If the problem persist, call a technician.
E83	BOILER 2 LEVEL	One level sensor of the boiler 2 can be broken. Reset the alarm for resume the program interrupted before. If the alarm persist, call the technician.
E84	BOILER 1 LEVEL	A boiler1 level probe might be broken. Reset the alarm. If the problem persists, please contact a technician
E85	OVERCHARGE	An overheating or an overload occurred. Please seek for technical assistance
E86	MAX T. BOILER 1	There might be a problem with the boiler heater contactor. Reset the alarm. If the problem persists, please contact a technician.
E87	BOILER CHARGE 1	There might be several reasons causing this alarm: the tap of hot water might be closed or only partially opened, the pipes might be clogged or there might be lack of water in the network. Reset the alarm. If the problem persists, please contact a technician.
E88	BOILER HEATING	There might be a problem with the boiler resistor. Check for the presence of limescale on the resistor. Reset the alarm. If the problem persists, please contact a technician.
E89	NO DISINFECTION	The instruments are not disinfected because the minimum disinfection value was not reached. Reset the alarm. If the problem persists, please contact a technician.
E90	DRAINAGE t. B.1	The discharge pipe of boiler 1 might be clogged or pinched or the discharge solenoid valve of boiler 1 might be broken. Reset the alarm. If the problem persists, please contact a technician.
E91	DRAINAGE t. B.2	The discharge pipe of boiler 2 might be clogged or pinched or the discharge solenoid valve of boiler 2 might be broken. Reset the alarm. If the problem persists, please contact a technician.
E92	MAX T. BOILER 2	It is a problem in the contactor of the heating elements of boiler 2. Reset the alarm to resume the program interrupted before. If the alarm persists, call a technician.
	PROGRAM INTERRUPTED NO DISINFECTION	Warning: the program was manually stopped and maybe instruments have not been disinfected.

#### 4 CYCLE COUNTER:

Connecting the computer to the machine, it is possible to see how many and which programs the machine executed since its installation. The "No. of cycles at control" indicates how many cycles the machine can perform before being subjected to scheduled maintenance.

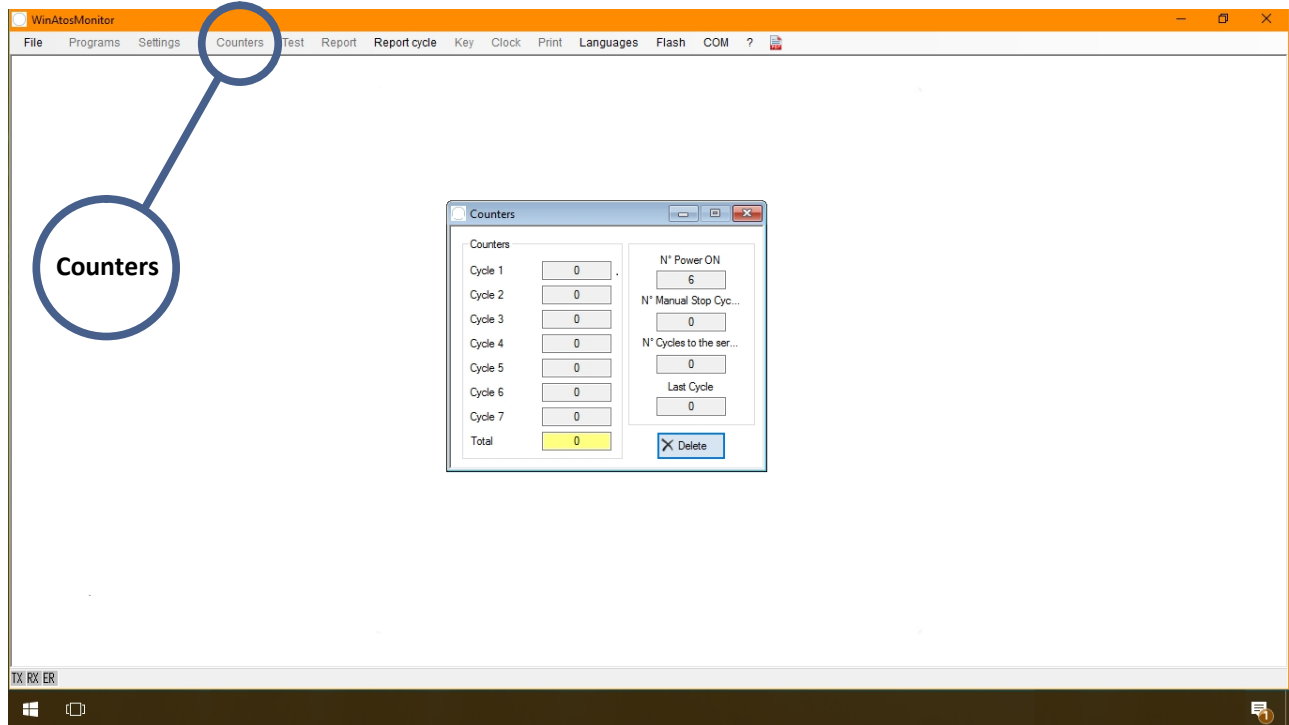

## 5 CHEMICAL PRODUCTS CALIBRATION



The number of hydraulic circuits for loading chemicals is variable depending on the machine configuration required by the customer.

The calibration of the chemical flowmeter should only be performed if using liquid chemical disinfectants other than those recommended by the manufacturer.

### 5.1 Preparation for calibration of chemical products:

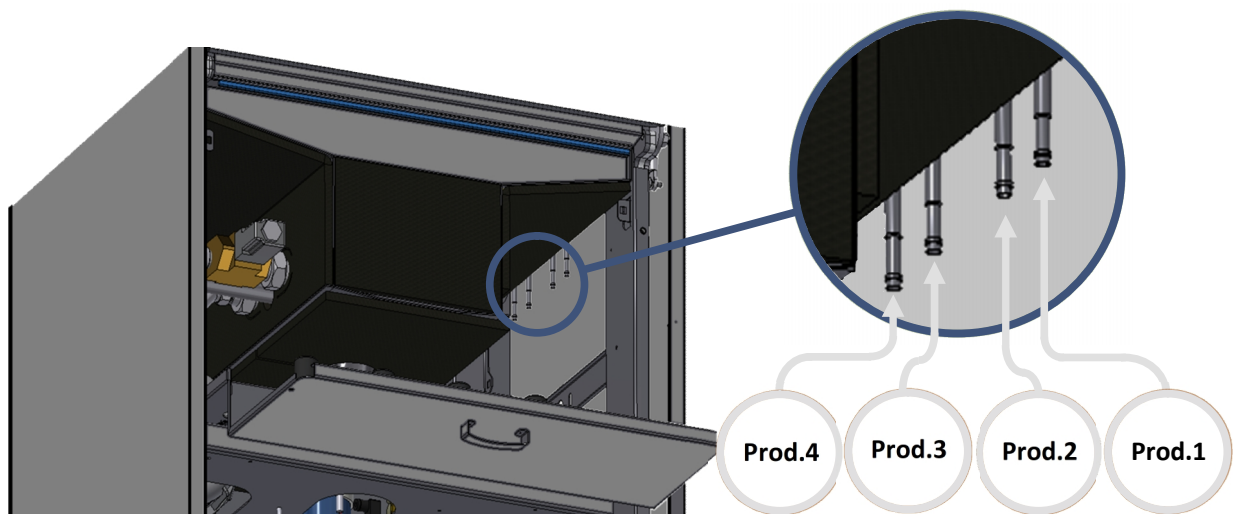

1. remove the lower panel and open the door of the peristaltic pumps by loosening the screws;

2. locate the flowmeter to be calibrated, disconnect the silicone hose from stainless steel connector. The calibration of the chemical flowmeter should only be performed if using liquid chemical disinfectants other than those recommended by the manufacturer.
3. take a 100mL beaker, place it on the door and insert the silicone hose that comes from the flowmeter;
4. insert the nozzle of the chemical disinfectant to be calibrated in the tank of the liquid;
5. go into the programming menu (PRG key): to search for a program → press key 1 or 2; to select a program → START key; to return to the menu → PRG key
6. look for the "chemical products" menu (keys 1 or 2) and select it (START key); select the "hydraulic circuit refill" program (START key);
7. select the pump to be calibrated;
8. press START to activate the pump;
9. stop the pump when the liquid comes out of the hose and goes into the beaker (RESET key);
  - a. drain the liquid from the beaker and proceed with the calibration.

## 5.2 Chemical products calibration:



The procedure must be done after completing the operations previously described in the previous paragraph.

1. Press PRG to go back in the menu;
2. Select the item "chemical product calibration" and press START;
3. Select the chemical that you want to calibrate, making sure that the silicone tube is inside the beaker;
4. Press START to start loading the liquid inside the beaker;
5. Press RESET when the liquid reaches 100 ml inside the beaker to stop the liquid loading;
6. Press PRG to return to the previous menu. In this way, the calibration just carried out will be saved in memory;
7. At this point the calibration of the product concerned is completed.

## 6 SETTINGS AND MESSAGES MENU

There are two USB sockets for machine programming on the side of the machine. The top USB socket is used to connect a PC and for using the "Win The manufacturer Instrument Wash" program, the bottom USB slot is used to transfer precompiled programs from/to a USB flash drive.

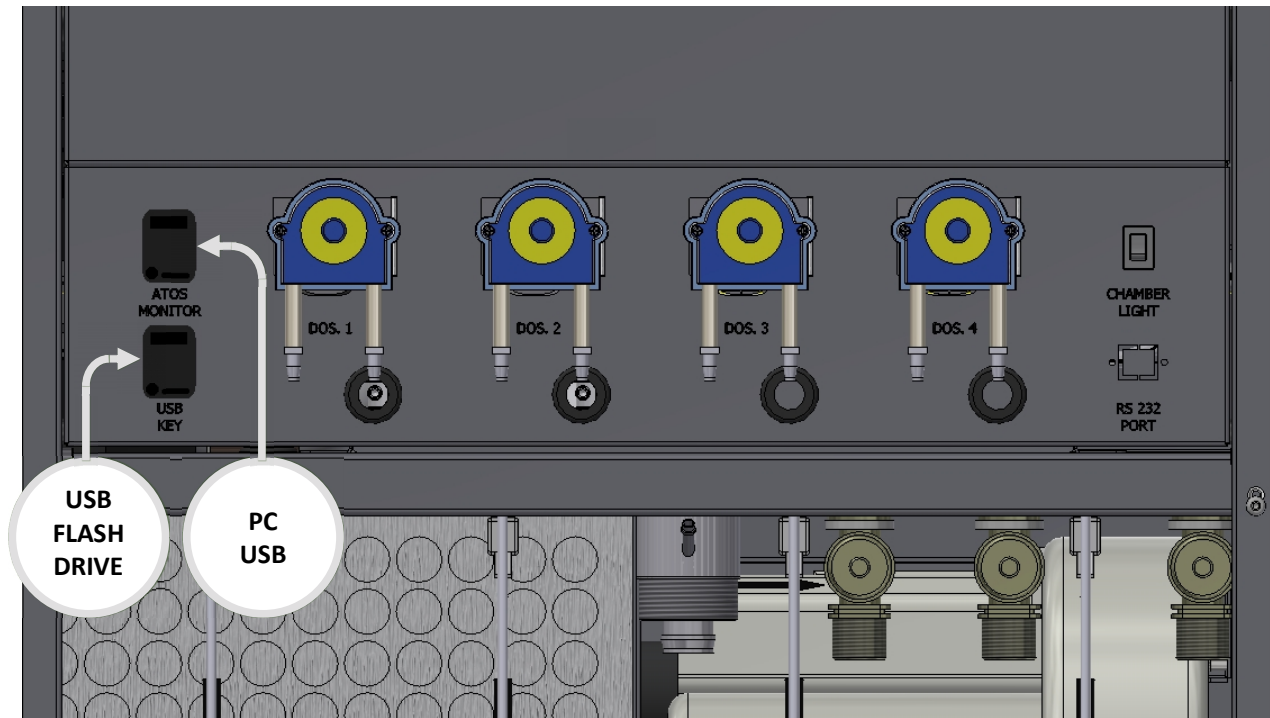

In order to be properly recognised by the device, the following folders must be created on the USB flash drive:

1. CARTAR = The dataset is put in this folder. The program must have .TRT extension (the file can be downloaded from the machine to the USB flash drive and uploaded from the USB flash drive to the machine)
2. CARTFWR = The firmware (basic instrument wash program) is put in this folder. The firmware must have .mh0 extension (the file can only be uploaded from the USB flash drive to the machine)
3. CARTMES = The file containing messages is put in this folder (displayed at the top of the display). This file must have .MSG extension (the file can be downloaded from the machine to the USB flash drive and uploaded from the USB flash drive to the machine)
4. CARTALM = The file with the list of the latest alarms is put in this folder by the machine (the file can only be downloaded from the machine to the USB file)

After inserting the USB flash drive into the bottom port, the following screen will appear:

SETTINGS: section to upload and / or download program files (calibration)

MESSAGES: section to upload and / or download message (of the upper part of the screen) files

ALARMS: section to download the most recent alarms list

FIRMWARE: section to upload a firmware file on the machine

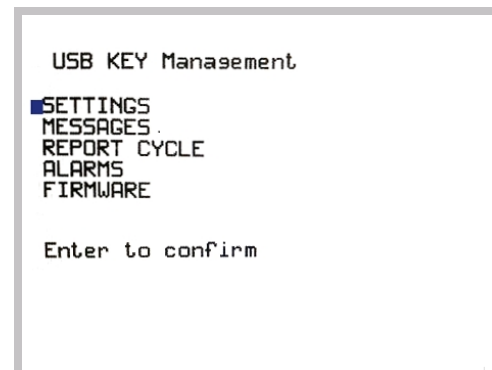

Press "1" or "2" buttons to scroll down the menu. Press the "3" to enter in the highlighted menu. Press the "RESET" button to return to the previous menu.



**SETTINGS:**

After entering the "settings" menu the user will have to choose between:

- WRITING: to download the program file from the machine to the USB flash drive;
- READING: to upload the program file from the USB flash drive to the machine;

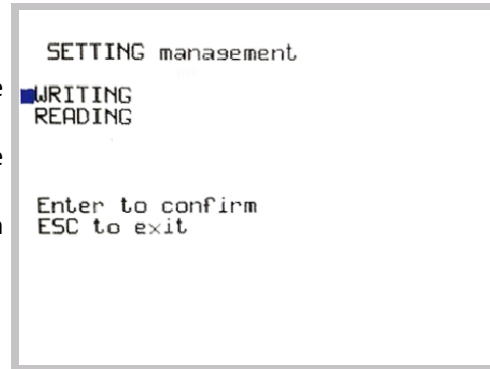

**SETTING \ WRITING:**

After selecting "WRITING", this screen will appear where the available space on the flash drive will appear along with the name of the file with which it will be saved on the flash drive. Press "1" to save the program file to the flash drive, otherwise press "reset" to return to the previous screen.

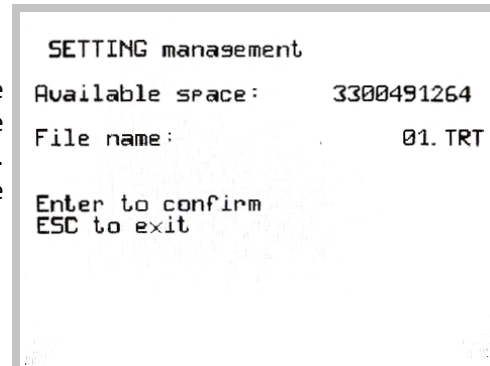

**SETTINGS/READING:**

After selecting "READING", the number of files in the "CARTTAR" folder will appear on the display, along with the name of the file. To scroll down and see the name of the other files, press "3". Once a file is selected, press "1" to install the program on the machine. To return to the previous menu, press "reset".

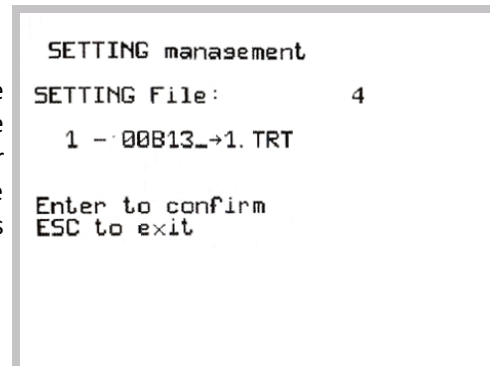

**MESSAGES:**

After entering the "Messages" menu, the user will have to choose between:

- WRITING: to download the message file from the machine to the USB flash drive;
- READING: to upload the message file (top of the display) from the USB flash drive to the machine;

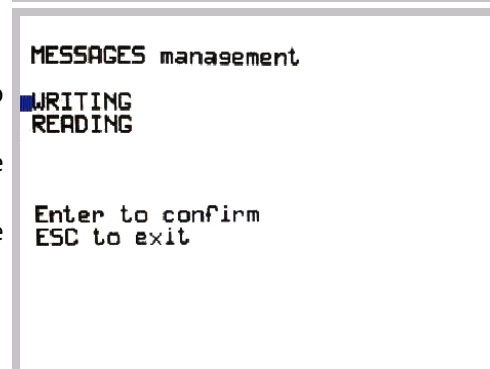

#### MESSAGES/WRITING:

After selecting "Writing", the available space on the flash drive will appear on the display, along with the name of the file that will be saved on the flash drive. Press "1" to save the program file to the flash drive, otherwise press "reset" to return to the previous menu.

```
MESSAGES managemet
Available space:    3300491264
File name:         01. MSG

Enter to confirm
ESC to exit
```

#### MESSAGES/READING:

After selecting "READING", the number of files in the "CARTMES" folder will appear on the display, along with the name of the file. To scroll down and see the name of the other files, press "3". Once a file is selected, press "1" to install the program on the machine. To return to the previous menu, press "reset".

```
MESSAGES managemet
MESSAGES File:    4
1 - PORTOG→1. MSG

Enter to confirm
ESC to exit
```

#### ALARMS:

After entering the "Alarms" manu, the available space on the flash drive will appear on the display, along with the name of the file that will be saved on the flash drive. Press "1" to save the program file to the flash drive, otherwise press "reset" to return to the previous menu.

```
ALARM managemet
Available space:    3300491249
File name:         01. EAL

Enter to confirm
ESC to exit
```

#### FIRMWARE:

After entering the "READING" menu, the number of files in the "CARTFWR" folder will appear on the display, along with the name of the file. To scroll down and see the name of the other files, press "3". Once a file is selected, press "1" to install the program on the machine. To return to the previous menu, press "reset".

```
FIRMWARE managemet
FIRMWARE File:    2
1 - FW0628→1. MH0

Enter to confirm 2
ESC to exit
```

## 7 MAINTENANCE

### 7.1 External cleaning of the machine:

Clean the surface of the device with **PRODUCTS SUITABLE FOR STAINLESS STEEL**. Products other than these can irreparably destroy not replaceable parts of the device, making the

machine completely unusable. If a suitable cleaning liquid product is not available, use a mixture of water (75%) and alcohol (25%). Cleaning should be done with a lint free cloth (that does not scratch), moistened with a suitable liquid. **DO NOT SOAK THE CLOTH** to prevent the exceeding liquid from penetrating into electrical areas dangerous for the operator. Clean the keyboard and the display with a mixture of water and alcohol or mild detergents. The washing tank is automatically cleaned. In case of need, for an extra cleaning of the washing chamber, run a rinse cycle without introducing instruments.

### 7.2 Cleaning of the filters inside the machine:

Clean **AT LEAST ONCE A WEEK** the filters positioned at the bottom of the tank to avoid drain obstructions ensuring machine full efficiency. Take the two filters by the handle and open them to remove dirt. Periodically check the level of liquid present in the tanks, in the lower compartment of the machine. When the liquid is nearly finishing a notice appears on the display. When the liquid is finished a message alarm is displayed. The machine is equipped with flow meters that detect the correct passage of the liquid. In case of abnormal flow interruption the alarm appears on the display.



Use personal protective devices for hands (PPE - gloves).

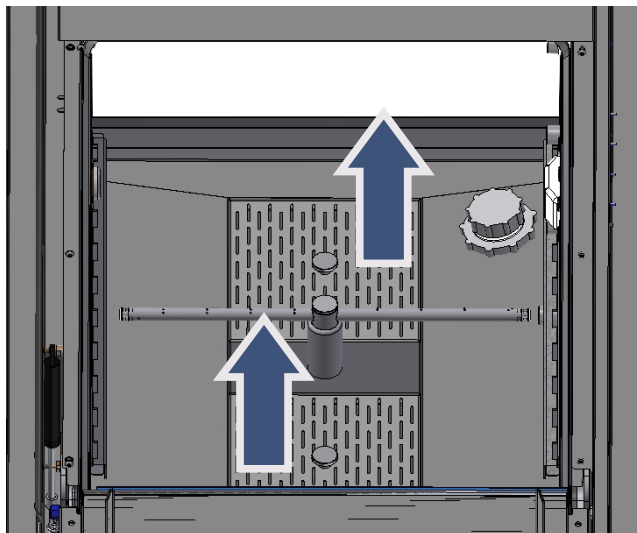

Unscrew the lower handle(1) to divide the two pieces that make up the filter (2).

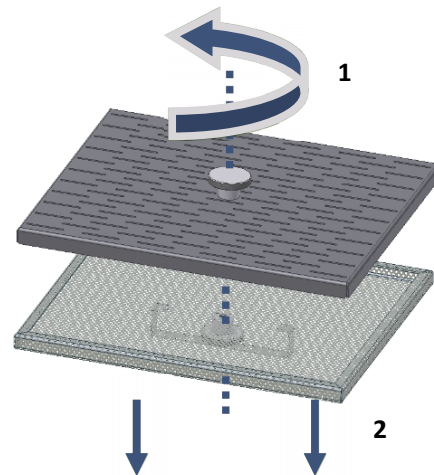

### 7.3 Cleaning of the filters for water loading:

Using the main switch on the side of the machine cut the power off. Close the water supply to the machine.

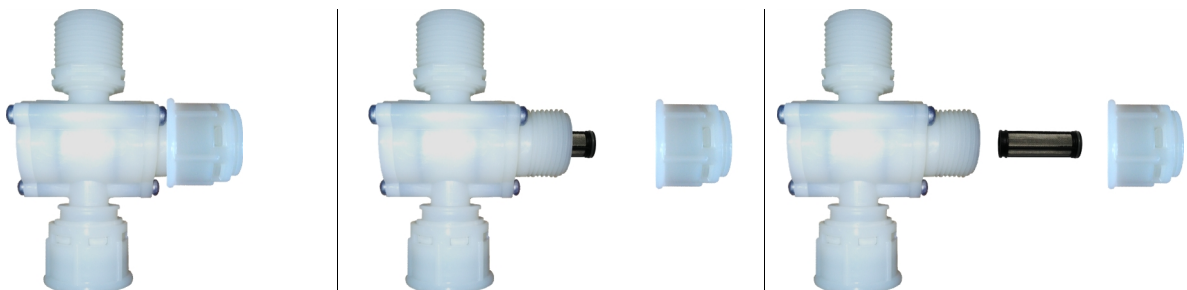

Open the lower compartment of the machine, inserting the plastic key into the lock on the bottom panel. Reach the filters and unscrew the caps (see pictures). Extract the cylindrical filter inside the cap, possibly clean it thoroughly with compressed air; in the same way, and clean the filter housing. Place the Hylindrical filter in its housing, taking care to insert the closed side facing the cap (the open side should enable the steel rod to fit inside the filter). Screw the cap on the housing and repeat for the other filter. Open the taps supplying water to the machine and restore power. Place the bottom panel in its seat.

#### 7.4 Cleaning of the Impeller:

Periodically check that the impeller holes are not obstructed so as not to compromise the washing. Verification is visual. Also check if the impeller remains locked and does not rotate. If the machine is equipped with the "impeller monitoring" application (optional), an alarm appears in the event of a blocked impeller. To clean the impeller, proceed as follows:

1. Grasp the bush above the impeller and hold it in place while unscrewing the impeller clockwise;

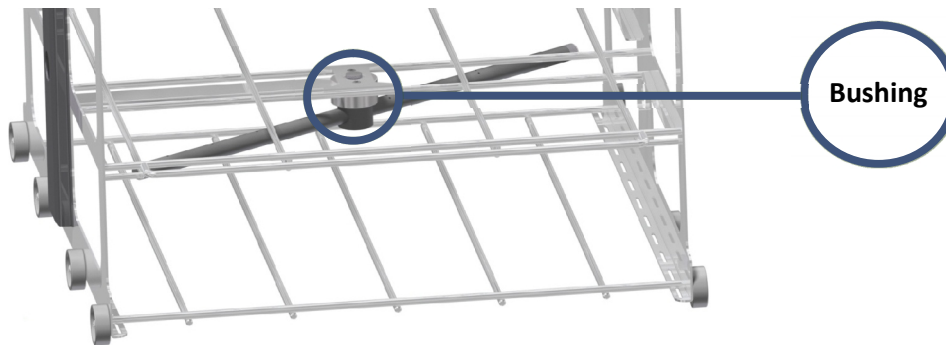

2. Unscrew the plastic plugs at the end of the impeller;

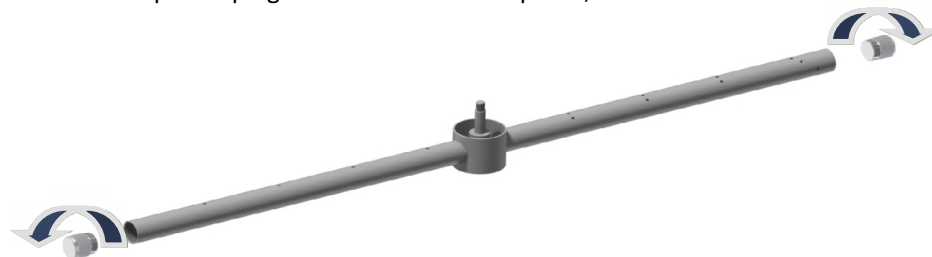

3. Check to see if there is any dirt inside the impeller which prevents the correct flow of water;
4. Clean the blocked holes with a jet of water;
5. Once the cleaning has been completed, screw the two plugs back onto the ends and screw the impeller back onto the carriage.

## 7.5 Door adjustment:

Any jolts or knocks during transport may misalign the door. The correct distance (H) between the door fixing bracket and the tank is the same on both sides. To adjust the door proceed as follows:

1. remove the side panel where the adjustment is to be made;
2. loosen the flange nuts on the door gusset;
3. adjust the bracket upwards or downwards while holding the door;
4. tighten the four flange nuts.

## 7.6 Door limit switch adjustment:

The door is in the correct position when it is flat (measured with a spirit level) while completely open with the wash trolley resting on it. To adjust the opening angle of the door:

1. loosen the flange screws that hold the brass block ;
2. place the brass block to the desired position and tighten the flange screws again.

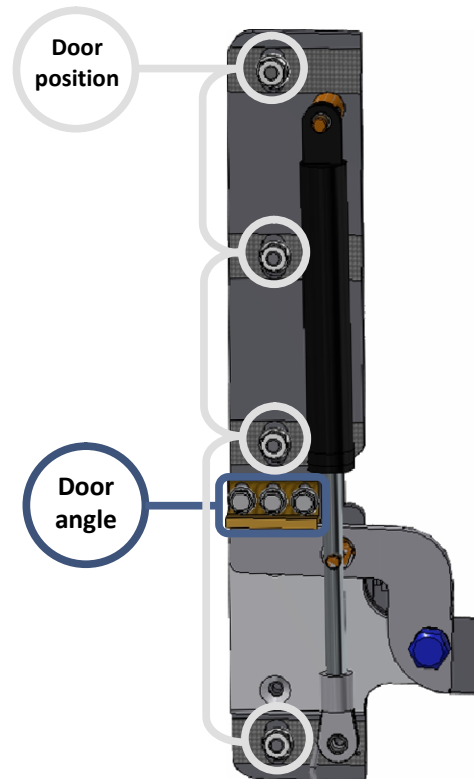

## 7.7 Door lock adjustment:

If there are still problems relating to the closure of the door, adjust the door lock bracket. The door lock could have the following problems:

- the door lock bracket makes contact with the door tang while closing;
- if during operation (door lock closed) the handle is rotated, the alarm activates incorrectly (because the microswitch that supports the tang is triggered)

To adjust, proceed as follows:

1. remove the touch screen panel (by unscrewing the three lower screws);
2. loosen the screws above the door lock bracket and move the bracket to the right or left, with the door closed, checking that, when the door lock is in the closed position, by moving the handle (tang located between the door lock bracket and the microswitch), the microswitch that rests on the tang is not triggered;
3. after the adjustment, tighten all the screws.



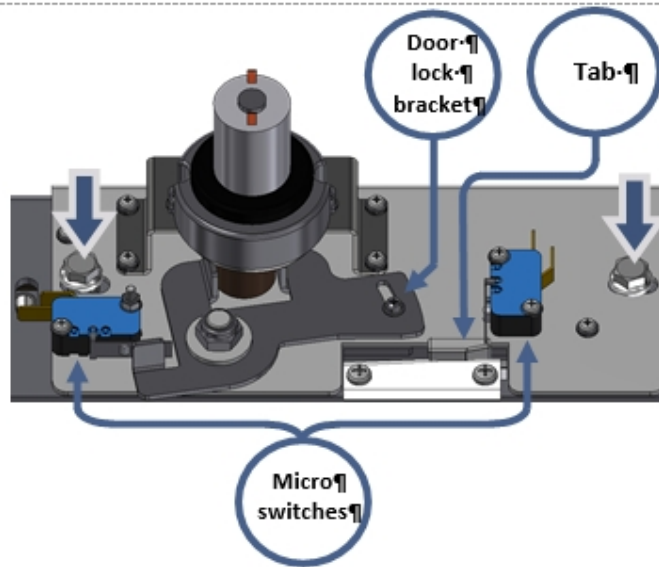

## 7.8 Periodic maintenance:



If the water supplied is high in calcium content, it is recommended to periodically carry out a general inspection and a cleaning of the device. Do not clean the device with direct water jets. Do not use products based on chlorine (bleach)

(\*: ACTIONS REQUIRED ONLY IN CASE OF MACHINE FAULTY OPERATION DURING TESTING)  
Please Note: maintenance operations must be carried out according to the number of cycles or to the operation time.



In order to avoid malfunctions or blocks, the machine requires regular periodic maintenance.



If you are unable to operate the machine even after routine/unscheduled maintenance please contact the MANUFACTURER customer service by specifying the nature of the fault, the model and the serial number of the machine.

The operator/user may enter into a service agreement with THE MANUFACTURER representative, to receive direct servicing. In addition, there is the possibility to have technical staff trained at THE MANUFACTURER premises. The technical service will be then able to carry out servicing independently, solving any technical problem.



To remove limescale only use adequate products. Do not use corrosive products not compatible with the materials constituting the machine.

EVERY	CYCLE	MONTHS						ACTIVITY	TIME
		6	12	18	24	30	60		
every	2000	X						Unscrew the impellers inside the tank and on the trolley in use, unscrew the plugs at the ends of the impellers and wash the inside checking that there are no impurities that obstruct the holes.	10'
every	2000	X						Visually check the integrity of the tank seal and check that there are no water leaks during the cycle.	10'
every	10000					X		With the machine turned off as a main switch, check that the power cable connections are intact and that they do not show oxidation.	5'
every	4000		X					Disconnect the machine from the building's water mains, remove the solenoid valves from the machine plant and clean the inside with water to remove impurities.	30'
every	4000		X					Check that the sliding float is not blocked and operates properly. Check that the entire lance circuit is working properly, so that there are no leaks.	15'
every	8000			X				Check that the springs prevent the door from closing abruptly, preventing it from banging against the casing of the machine during closing.	10'
every	8000			X				Check that the hooking of the tubes to the peristaltic pumps is firm and does not allow leakage of liquid.	15'
every	8000		X					Remove the machine from the building's water supply, remove the filters, open them and clean the inside with water to remove impurities.	25'
every	4000						X	Check the electrical consumption of the resistors, visually check their status inside the chamber, verify that there are no water leaks from the electrical connections in view on the back of the tank.	20'
every	12000						X	Check that there are no water leaks.	40'
every	12000		X					Check that there are no constructions inside that does not allow correct operation.	15'

<b>PART</b>	Impellers in the chamber	Seal of chamber	Power connections on the panel	Solenoid valves loading water	Suction noozles	Gas springs	Pipes for loading products	Water filters	Heating elements inside the chamber	Washing pump stuffing box.	peristaltic pumps
-------------	--------------------------	-----------------	--------------------------------	-------------------------------	-----------------	-------------	----------------------------	---------------	-------------------------------------	----------------------------	-------------------

## 8 TEMPERATURE TEST

To carry out the test temperature the operations listed below are required:

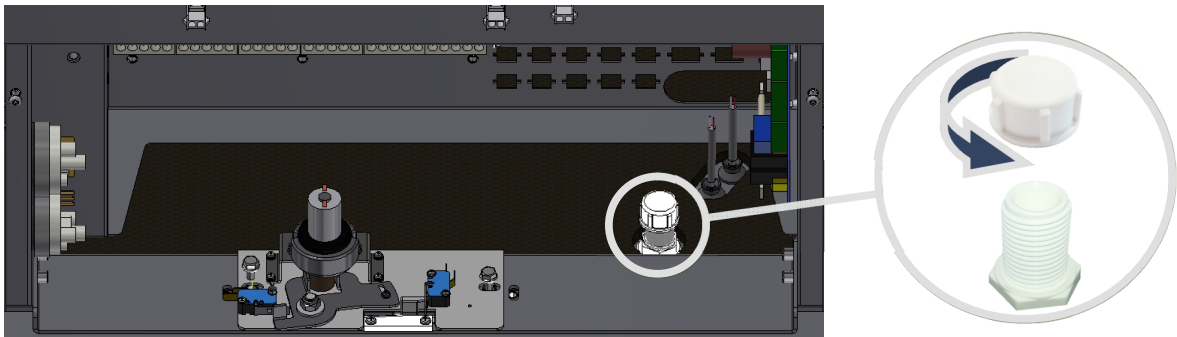

1. Cut OFF the power supply;
2. Remove the top panel from the machine;
3. Turn ON the machine;
4. Unscrew the white cap from the hole for inspections inside the chamber;
5. Insert the thermocouple for the temperature testing and start one of the programs;
6. Check the temperature changing in the time, paying particular attention during the disinfection phase;
7. When the test is complete, Cut OFF the power again. Take the thermocouple away from the inspection hole and screw the tap again.
8. Then assemble again the top of the machine ;
9. Turn the power supply ON again; therefore the test is finished.



# DIAGRAMS



E

Cat. No. MAN205-0715001EN Rev. A  
COPYRIGHT ©